

LifeDop

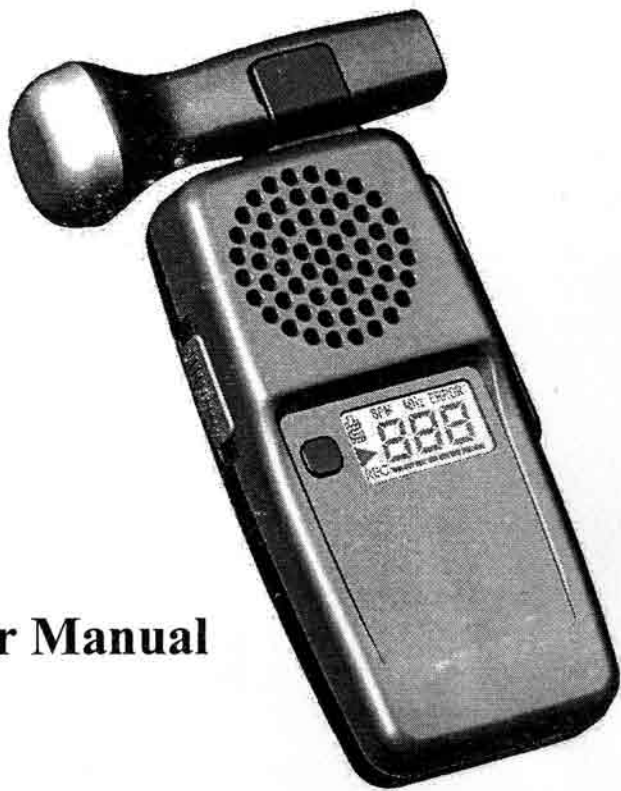

User Manual

SummitDoppler

Listening to Life™

Intended use

Obstetric (2 and 3 MHz Probes)

This product will be used to detect fetal heart beats as an aid for determining fetal viability.

Vascular (4 and 8 MHz Probes)

This product will be used to detect blood flow in veins and arteries for assisting in the detection of peripheral vascular disease.

Federal law restricts this device to use by or on the order of a physician.

Contraindications

Warning: The vascular probes (4 and 8 MHz) are not for fetal use.

Warning: The ultrasound probes are not to be used on or near the eyes.

Warning: The device is for use only on intact skin.

Warning: Do not plug any part of this device into a telephone or modem system.

Warning: This device is not intended for use with HF surgical equipment.

If there are questions or concerns regarding these warnings or contraindications, please do not hesitate to contact Summit Doppler Systems for further clarification.

Safety of Ultrasound

Summit dopplers were designed with physician and patient safety in mind. In early design phases all potential hazards were eliminated or reduced to As Low As Reasonably Achievable (ALARA) by adhering to good design practices and industry wide safety standards. Ultrasound procedures should be performed with the ALARA principle in mind when delivering ultrasound energy into the body.

The following official statements from the American Institute of Ultrasound Medicine (AIUM) are provided for your general information regarding the safe use of ultrasound.

Clinical Safety

Approved March 1997, October 1982

Diagnostic ultrasound has been in use since the late 1950s. Given its known benefits and recognized efficacy for medical diagnosis, including use during human pregnancy, the American Institute of Ultrasound in Medicine herein addresses the clinical safety of such use:

There are no confirmed biological effects on patients or instrument operators caused by exposures from present diagnostic ultrasound instruments. Although the possibility exists that such biological effects may be identified in the future, current data indicate that the benefits to patients of the prudent use of diagnostic ultrasound outweigh the risks, if any, that may be present.

Prudent Use

Approved May 1999

The AIUM advocates the responsible use of diagnostic ultrasound. The AIUM strongly discourages the non-medical use of ultrasound for psychosocial or entertainment purposes. The use of either two-dimensional (2D) or three-dimensional (3D) ultrasound to only view the fetus, obtain a picture of the fetus or determine the fetal gender without a medical indication is inappropriate and contrary to responsible medical practice. Although there are no confirmed biological effects on patients caused by exposures from present diagnostic ultrasound instruments, the possibility exists that such biological effects may be identified in the future. Thus ultrasound should be used in a prudent manner to provide medical benefit to the patient.

Safety in Training and Research

Approved March 1997, March 1983

Diagnostic ultrasound has been in use since the late 1950s. There are no confirmed adverse biological effects on patients resulting from this usage. Although no hazard has been identified that would preclude the prudent and conservative use of diagnostic ultrasound in education and research, experience from normal diagnostic practice may or may not be relevant to extended exposure times and altered exposure conditions. It is therefore considered appropriate to make the following recommendation:

In those special situations in which examinations are to be carried out for purposes other than direct medical benefit to the individual being examined, the subject should be informed of the anticipated exposure conditions, and of how these compare with conditions for normal diagnostic practice.

Description of product

The Summit LifeDop doppler is factory configurable to include many different features and product enhancements. Along with user interchangeable ultrasound transducers, the Summit Doppler device is well suited to meet your specific needs.

Main Unit

The main handheld unit is ergonomically designed to fit the palm of your hand with comfort and allow easy access to each control feature. Each unit is individually tested and inspected to ensure the highest quality standards.

SSQ – Superior Sound Quality. Every Summit Doppler is designed with a state of the art sound system that produces excellent sound quality and long-term reliability.

Recharge – We offer the ease of use of a rechargeable system or the attractive cost of a non-rechargeable unit. Either way, the LifeDop doppler battery system has been designed with your long-term battery life needs in mind.

LCD Display – The LCD display (optional) allows you to view the fetal heart rate in larger easy to read digits, monitor battery life and battery recharging, observe signal strength indicators, Play/Record functions, and multiple diagnostic indicators that ensure your unit is functioning at peak performance levels.

Units without LCD display incorporate bright, easy to read LED indicators that also allow you to monitor battery life, battery recharging and Play/Record functions as appropriate to your unit.

Record – This unique built in enhancement allows you to record doppler sounds during an examination and refer to these sounds for later evaluation, replay for parents or colleagues, or download the audio to a PC for permanent storage or e-mail.

Main Unit Catalog#	Feature			
	SSQ	Recharge	Display	Record
L150	X			
L150R	X	X		
L150A	X			X
L250	X		X	
L250R	X	X	X	
L250AR	X	X	X	X

Probes

Summit Doppler ultrasound transducers were designed to meet your specific applications needs. Each probe has been ergonomically designed for comfort while providing excellent maneuverability for locating the fetus or vascular target.

Each probe is carefully measured and tested to ensure it meets exacting performance standards.

2 MHz - Late term obstetrical examination. This probe frequency is typically used during the last trimester for deep fetal positions associated with larger women.

3 MHz – Early and general-purpose obstetrical examination. This probe frequency is a general use model ideal for most stages of fetal examination. Fetal heart sounds can be heard as early as 12 weeks and sometimes sooner depending on the position and size of the fetus.

4 MHz Broad – This unique peripheral vascular probe is ideal for quickly locating brachial, radial and ankle arteries in the performance of Ankle/Brachial Index testing. The broad beam of the 4 MHz probe allows the user to place the probe over the general location of the artery and with very little movement find the vessel for fast blood pressure measurements.

8 MHz Tip – This standard “pencil” style probe is an excellent vascular tool for locating specific vessels in the peripheral vascular system. The narrow grip and small face of the probe make it ideal for maneuvering for maximizing the signal.

Probe Catalog #		Application			
		Late OB	General OB	PV ABI	PV General
P200	2 MHz	X			
P300	3 MHz		X		
P400	4 MHz			X	
P800	8 MHz				X

Operation and Installation

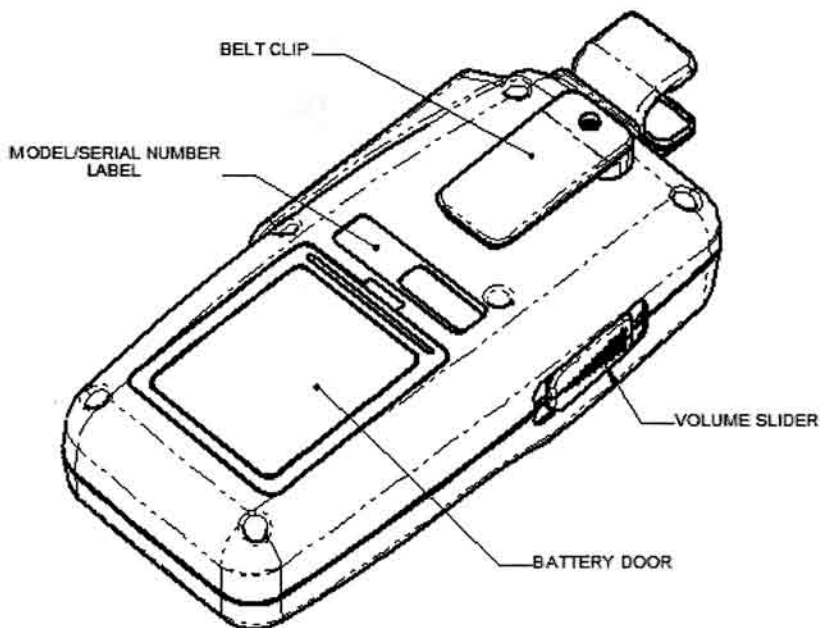
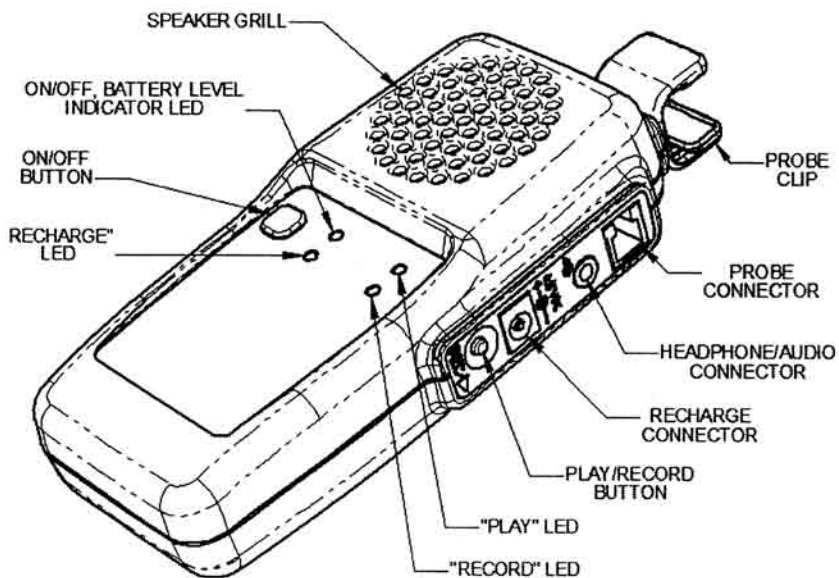

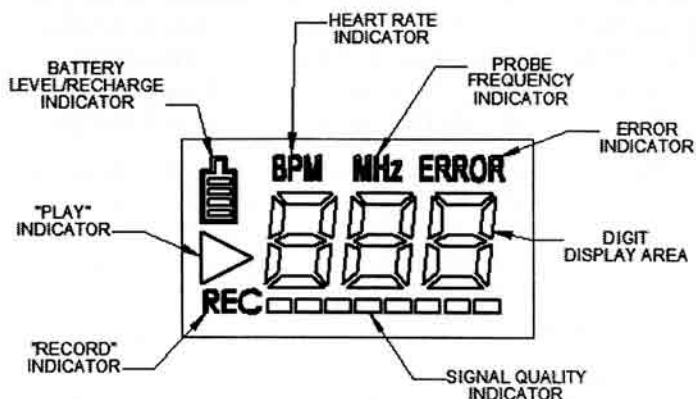

LCD Panel for Display Units Only

Turning Unit On/Off

Turn the unit on by pressing the On/Off button. LED or LCD indicators (depending on the model) indicate power status.

The LifeDop automatically shuts itself off after 3 minutes if it is not being used. This complete power shutdown preserves the life of the batteries and ensures the unit will be ready for operation in case it was accidentally left on.

Diagnostic Monitoring (LCD Display units only)

Once the unit is on, the LifeDop display units perform a series of diagnostic checks. The unit first checks and temporarily displays the frequency of the probe that is being used. This display will not reappear unless the probe is changed or the power is cycled, in which case the display will again temporarily confirm the frequency of probe that is connected.

The unit then checks for proper internal operating temperature, battery voltage, reference voltage and power supply voltage levels. If any of these characteristics are out of range, the display will show the ERROR icon and a failure code associated with the diagnostic error. Diagnostic functions are periodically checked while the unit is on to ensure the doppler is operating at peak performance. Refer to the Trouble Shooting section for a listing of failure codes.

Battery Monitoring

All LifeDop doppler units perform continuous battery monitoring and give a visual indication of battery level. Display units use a multiple level battery shaped icon that indicates the voltage level of the battery. The battery outline will flash when the battery level is very low indicating that the user should change the batteries soon after the current examination is complete.

Non-display units use the On/Off LED as a battery indicator by flashing at a low rate (approximately once per second) when the battery level is low. Several exams can still be performed in this state of operation. The battery indicator will flash at a higher rate (approximately twice per second) when the battery level is very low. The user should change the batteries soon after the current exam is complete.

Recharging (Rechargeable units only)

Warning: Do not use any other wall adaptor unit other than that supplied by Summit Doppler Systems. See accessories list for part number and re-order information.

Warning: Do not attempt to recharge alkaline batteries.

To recharge the unit, plug the recharge jack from the wall adaptor into the unit's recharge connector. For display units, the battery shaped icon will cycle in a repeated rising pattern to indicate the unit is recharging. For non-display units, the Recharge LED will turn on.

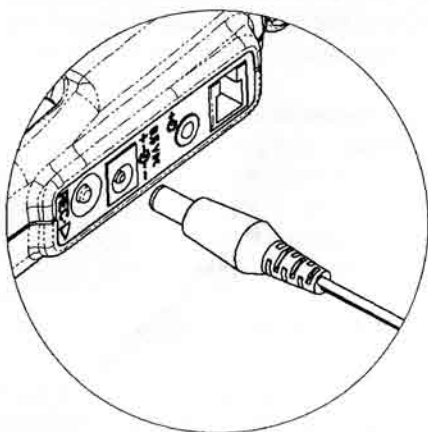

**Recharge Jack from
power supply plugs
into connector**

8.5 VDC
+ — — —

The recharge cycle will be limited to 14 hours or until the maximum battery voltage level has been reached. Once the recharge cycle has been discontinued normally, the LCD icon or the Recharge LED will flash at a low rate. The unit will not overcharge the batteries. If it determines that the batteries do not require charging, the charge cycle will be interrupted after 30 seconds.

Play and Record (Record units only)

Caution: To distinguish between live audio and playback audio refer to the Play icon or Play LED. If the indicator is on, the sound is coming from a recorded signal.

Play

To listen to a pre-recorded audio file on the LifeDop doppler, press and release the Play/Record button on the side of the unit. For display units, the Play icon is on during playback. For non-display units, the Play LED is on during playback. The recorded audio files are not re-processed for heart rate calculation - heart rates must be determined manually in the play mode.

The unit will continue to play the recorded audio until either the end of the stored data, or until the Play/Record button is pressed again. This will stop the playback audio and the unit switches back to real time audio when the indicators turn off. Volume control remains functional during playback.

Record

To record a new audio file on the LifeDop doppler, obtain the desired Doppler signal and press and hold the Play/Record button until the Record LCD icon, or Record LED comes on (approximately 4 seconds). Once the icon has turned on and the button is released, the Doppler signal will be stored for 32 seconds or until the Play/Record button is pressed again. Either of these events will stop the recording audio mode.

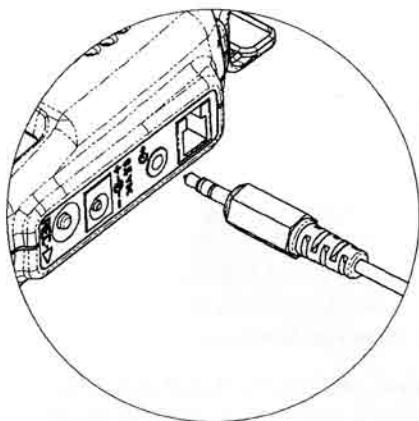

Press Button to play,
hold 4 seconds to record
REC • ▶

Audio Jack from
cable plugs into
output connector
◀ ⊕

Recording a new audio file automatically overwrites any previous recording.

Download to Personal Computer (Sound Card Required)

Warning: The audio/headphone output should only be connected to external line powered accessories that comply with recognized safety standards such as IEC601-1, IEC60065, UL2601-1 or UL544.

Warning: The LifeDop doppler is not specified for connection to any line powered accessories while it is being used on a patient.

For use with IBM style PC's (using MicroSoft™ Windows™)

To download the audio to a PC for permanent storage, connect one end of the provided 3.5 mm audio cable into the Audio Out jack on the side of the Summit LifeDop. Connect the other end of the cable into your PC sound card "Audio In" port - typically the blue connector on the sound card.

Using operating system Windows 98 or higher, on your PC select the Sound Recorder Application by selecting: START MENU, PROGRAMS, ACCESSORIES, ENTERTAINMENT, SOUND RECORDER.

Click on the highlighted RECORD icon in the Sound Recorder Application to start recording.

Press the Play button on the side of the Summit Doppler. The audio should now be playing and the PC downloading the audio information as indicated by the graphical sound waveform.

If the sound waveform is a flat line while you are hearing the audio from the LifeDop, then the recorder input is not selected properly. To choose the proper input, open the Volume Control Application by selecting: START MENU, PROGRAMS, ACCESSORIES, ENTERTAINMENT, VOLUME CONTROL.

Click on Options and then Properties. Click on Recording and ensure that the LINE IN box is checked, then click OK. In the Recording Control Screen, click the to ensure the Select Box for LINE IN is selected and then exit. The recorder is now set up to use the audio as an input. Restart the Sound Recorder Application and record as directed above.

When the audio playback is finished, click on the STOP icon in the Sound Recorder. The file can be played back on the PC by clicking the PLAY icon in the Sound Recorder or the file can be stored by selecting FILE, SAVE AS to locate and name the file.

Refer to your PC User's Manual for problems associated with the sound card or Sound Recorder Application.

For use with Apple™ Macintosh™

To download the audio to a PC for permanent storage, connect one end of the provided 3.5 mm audio cable into the Audio Out jack on the side of the Summit LifeDop. Connect the other end of the cable into your Mac sound card "Audio In" (microphone) port.

On your Macintosh, open the SimpleSound Application that is usually found in the Apple Menu. If you are unable to locate the application in the Apple Menu, do a FIND for "SIMPLESOUND".

Once you open SimpleSound, an AlertSounds box may be shown. Select File and then New to open a new audio file.

Click on the highlighted RECORD icon in the application to start recording.

Press the Play button on the side of the Summit Doppler. The audio should now be playing and the Macintosh downloading the audio information as indicated by the graphical waveform from the Speaker icon.

If there is no graphical waveform from the Speaker icon while you are hearing the audio from the LifeDop, then the recorder input is not selected properly. To choose the proper input, return to the Apple Menu and open the Control Panel. Open the Sound Application and select Input. Set "External Mic" as the built in sound source.

The recorder is now set up to use the audio as an input. Restart the SimpleSound Application and record as directed above.

When the audio playback is finished, click on the STOP icon in the recorder. The file can be played back by clicking the PLAY icon in the recorder or the file can be stored by selecting SAVE to locate and name the file.

Refer to your Macintosh User's Manual for problems associated with the sound card or Simple Sound Application.

Obtaining Doppler Signals

Caution: Doppler examinations should be performed only by trained individuals.

For any doppler examination, it is essential that an adequate supply of coupling gel is used to transmit the ultrasound energy from the probe to the surface of the skin. Re-apply more gel if it starts to dry out or spread so thinly that an air gap occurs between the probe and the skin. It is not necessary to cover the entire surface of the probe, only the probe face. Applying too much gel makes the unit difficult to clean and does not aid in the performance of the probe.

Volume Slider

The audio level can be adjusted using the Volume Slider. Moving the slider up will increase the volume, while moving it down will decrease it.

Signal Quality Indicator (Display units only)

An inadequate signal can produce erroneous rates from the heart rate calculation. The signal level that is being obtained is shown on the Signal Quality Indicator bars. This indicator provides a visual aid in obtaining a strong audio signal by showing the pulsatile nature of the signal. A large difference between the highest and lowest signal bars that are lit confirms that the quality of the signal is good and thus ensures the heart rate calculation is operating at peak performance.

The heart rate can be verified manually by counting the audible beats for 20 seconds and multiplying by 3, or for 15 seconds and then multiplying by 4. Counting for less than 15 seconds is not recommended due to a decrease in accuracy with the small sample size.

Obstetrical

Fetal heart sounds are quite different from peripheral vascular blood flow sounds. Fetal sounds are typically much lower in frequency and much higher in rate. For early term fetal detection, start the probe at the pubic bone and slowly move along the midline – rocking the probe slowly from side to side until a heart beat is heard. For mid to late term fetal detection the best chance of finding the heart sounds are to start on the fundus and move toward the navel and from one side of the abdomen to the other, slowly rocking the probe until the heart beat is heard. The fetal heart reminds many people of a galloping horse and can vary in tone from a distant swishing sound to a hard clopping sound depending on the position of the baby and probe.

Many times when attempting to detect the fetal heart, the maternal vascular sounds are heard instead of (or in some cases, in addition to) the fetal sounds. These maternal sounds can come from one of the major arteries, the placenta or the umbilical cord. The maternal vascular sounds are typically higher in frequency at a lower rate. The heart rate calculation will display either the maternal rate or the fetal rate, whichever portion of the signal is stronger.

If the fetal heart sounds cannot be located using the Summit Doppler procedure as described above, a second exam should be performed using another commercially available fetal monitor as a repeated test.

8 MHz Vascular

Peripheral arterial sounds are typically higher in frequency. For the best sounds, angle the probe approximately 45 degrees from the skin surface over the general location of the vessel. Slowly move the probe side to side and vary the angle of the probe until the vascular sounds are heard. Changing the angle of the probe has an affect on the frequency of the sound. The steeper the probe angle is, the higher the frequency of the sound.

Peripheral venous sounds are not typically periodic and vary greatly depending on patient movement and breathing. These sounds are more like the wind at the ocean and vary in pitch as the patient moves or breaths.

4 MHz Vascular

The use of the 4 MHz vascular probe is the same as the 8 MHz as described above, except tilting the probe 45 degrees is not necessary since the crystals are angled inside the probe cap. This allows the user to simply place the probe flat on the peripheral vascular surface to scan for the flow sounds by moving the flat probe face across the skin surface above the vessel.

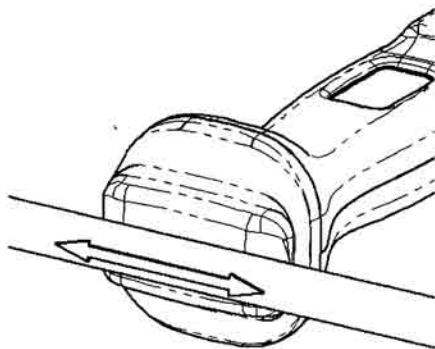

**Proper alignment of
the 4 MHz vascular
probe with respect
to the vessel**

Maintenance and Cleaning

Warning: The LifeDop is not designed for liquid immersion. Do not soak or drop the Doppler main unit or probes in liquids.

Warning: The LifeDop is not designed for sterilization processes such as autoclaving or gamma radiation.

Warning: The LifeDop is not intended to be used on open skin. If there is evidence of open wound contamination, disinfect the probe before using again as described below.

The LifeDop Doppler requires very little maintenance. However, it is important to continuing function of the unit and the health of the patients that the unit is cleaned and examined regularly per the following guideline:

After every examination:

Excess gel should be wiped off prior to docking the probe. Probes and main unit should be cleaned with a damp (not dripping wet) warm water cloth. Mild soap or detergent can be used. In particular, pay close attention to clean the seams along the plastic lines at the probe face but do not allow water to enter through the connectors or speaker grill.

Examiners should wash hands and change gloves after every exam. Refer to local and hospital policies for cleaning and disinfection policies.

To disinfect unit, use presaturated isopropyl alcohol (IPA) wipes or an IPA spray such as Transeptic from Parker Laboratories. Follow manufacturers instructions and wipe unit until it is dry of solutions.

Store unit in a clean area free from dust and debris. Follow temperature and humidity guidelines as specified at the end of this manual.

Warning: If the unit is to be stored for longer than 90 days without use, remove the batteries prior to storage.

Periodically (at least annually):

Inspect the main unit and probes for signs of cracks or breaks in the mechanical housing. Inspect cables and connectors for signs of wear or failure. The user should discontinue use of the unit with any sign of loss of housing integrity. Contact Summit Doppler Systems for service.

It is recommended that rechargeable batteries be replaced annually.

Replacing Batteries

Warning: Replace rechargeable batteries only with batteries supplied by Summit Doppler Systems. See accessories list for part number and re-order information.

Warning: The battery compartment only accepts AA size batteries. See accessories list for part number and re-order information.

Open the battery compartment by depressing the tab and pulling outward on the battery door. Remove the existing drained batteries by pushing on the end of the battery that compresses the battery contact spring and lift upwards. It is acceptable to carefully use a simple tool, such as a pen, to assist in lifting the batteries out.

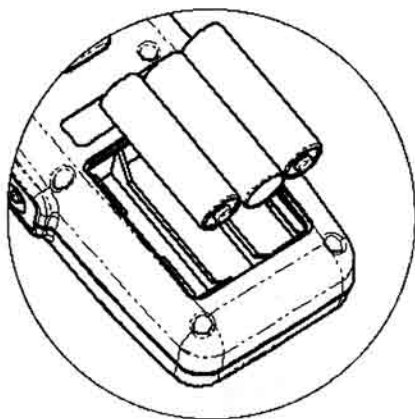

Batteries slide into compartment

Replace the batteries by paying close attention to the polarity indicators on the battery and the polarity indicators on the battery holder in the compartment. Positive (+) aligns with positive (button) and negative (-) aligns with negative (spring). Insert the battery such that the spring contacts are loaded first and then press the battery firmly into place. After all three have been inserted, replace the battery door.

Warning: If the batteries have been inserted incorrectly, the unit will not function but the LifeDop will not be damaged.

Trouble shooting

Warning: Use alternate equipment in case of unit failure. Call Summit Doppler Systems Service Department if the probe or main unit malfunctions.

Poor sound quality

Inadequate gel use

Try and relocate the probe for a better signal

Improper choice of probe Frequency

Interference from other equipment

Heart Rate inaccurate

Try and relocate the probe for a better signal – refer to Signal Strength indicator

For OB, ensure maternal sounds are not mixing with fetal sounds

Ensure by manual counting that the rate is between 50 and 210 BPM

Battery indicator flashing

Consult Battery Monitoring, replace batteries as described in Replacing Batteries

Probe frequency does not match the connected probe

Check probe that is attached to ensure it is the correct one

If correct probe, contact Summit Service

Probe frequency 0.0

No probe is attached

If probe is attached, contact Summit Service

Charging stops after 30 seconds

Batteries are not low. They do not require additional charge.

Recharge indicator flashing

Recharge cycle is complete or the batteries didn't require recharge

Recharge indicator off after charging

Battery level error has occurred – refer to Diagnostic Codes and contact service

Rechargeable unit does not hold a charge

Verify that the correct recharge adaptor is being used - Use only Summit Doppler Part Number PSA0001.

Batteries are old - Refer to Maintenance Section.

Radio Frequency Interference

The LifeDop was tested for immunity to electromagnetic interference at a level of 3V/meter. Interference during normal operation may occur in the presence of fields stronger than 3V/meter. If this occurs, try to increase the distance between the LifeDop and the source of interference. Contact Summit Doppler for more information.

Diagnostic Codes – Contact Summit Service

1 – Temperature too low	5 – 5 Volt Supply too low
2 – Temperature too high	6 – 5 Volt Supply too high
3 – Reference Voltage too low	7 – Battery Voltage too low
4 – Reference Voltage too high	8 – Battery Voltage too high

Reference materials for Obstetrical and Peripheral Vascular testing:

Handbook of Fetal Heart Rate Monitoring; Julian T. Parer, 1997

Doppler Ultrasound and Its Use In Clinical Measurement; Peter Atkinson and John P. Woodcock, 1982

Noninvasive Diagnosis of Peripheral Vascular Disease; W. Robert Felix, Jr., 1988

Current Noninvasive Vascular Diagnosis; Ali F. Aburahma, Edward B. Diethrich, 1988

Specifications

Level of protection against electric shock:



Type B Applied part



Class II Equipment

Safety tested to meet:

IEC601-1, IEC60601-1-2, IEC60601-1-4, IEC60601-2-37, CISPR 11-B

Dimensions (h w l): 140 x 70 x 35 mm

Weight: 320 grams

Operating temperature: 10 to 40 C

Operating humidity: 30 to 75 %

Transport/Storage temperature: -20 to 50 C

(beyond 30 days, battery to be stored between -20 and 30 C)

Transport Storage humidity: 5 to 90%, non-condensing

Battery voltage, type 3 – AA Alkaline 1.5 volt (non-rechargeable)
3 – AA NMHi 1.5 volt (rechargeable)

Battery life: Batteries provided by Summit Doppler:
1000, 1-minute exams (NMHi)
1250, 1-minute exams (Alkaline)

Audio bandwidth and power: 350 Hz – 2 KHz, 0.5 W

Record sampling rate, duration: 4 KHz, 32 seconds

Heart rate calculation accuracy: +/- 3 BPM over range 50 to 220 BPM

Audio cable pin out: 3.5 mm stereo plug
(record versions only) Tip – Audio out
Ring – Audio out
Shaft – Ground

Operating Conditions: There are no user controls which affect the ultrasound output.



Attention: Consult Accompanying Documents

Additional technical information is available upon customer request.

Transducer Model: LifeDop 4 MHz
Operating Mode: Continuous-Wave (cw)
Application(s): Peripheral Vascular

<i>ACOUSTIC OUTPUT</i>		<i>MI</i>	<i>I_{SPTA.3}</i> (mW/cm ²)	<i>I_{SPPA.3}</i> (W/cm ²)	
Global Maximum Value		0.05	278	.278	
Associated Acoustic Parameter	P _{r.3} (Mpa)	0.07			
	W ₀ (mW)		47.2	0.047	
	f ₀ (MHz)	4.0	4.0	4.0	
	Z _{sp} (cm)	1.2	1.2	1.2	
	Beam Dimensions	x ₋₆ (cm)		0.5	0.5
		y ₋₆ (cm)		1.0	1.0
	EBD	Az (cm)		0.45	
Ele. (cm)			1.15		

Transducer Model: LifeDop 8 MHz
Operating Mode: Continuous-Wave (cw)
Application(s): Peripheral Vascular

<i>ACOUSTIC OUTPUT</i>		<i>MI</i>	<i>I_{SPTA.3}</i> (mW/cm ²)	<i>I_{SPPA.3}</i> (W/cm ²)	
Global Maximum Value		0.02	140	0.14	
Associated Acoustic Parameter	P _{r.3} (Mpa)	0.07			
	W ₀ (mW)		5.5	0.006	
	f ₀ (MHz)	8.0	8.0	8.0	
	Z _{sp} (cm)	0.66	0.66	0.66	
	Beam Dimensions	x ₋₆ (cm)		0.2	0.2
		y ₋₆ (cm)		0.4	0.4
	EBD	Az (cm)		0.3	
Ele. (cm)			0.6		

- I_{SPTA.3}** the **derated spatial-peak temporal-average intensity** (mwatts per cm²).
I_{SPPA.3} the **derated spatial-peak pulse-average intensity** (watts per cm²).
MI the **Mechanical Index**.
P_{r.3} the **peak rarefactional pressure** (megapascals) associated with the transmit pattern giving rise to the value reported for MI.
W₀ the total time-average **ultrasonic power** (mwatts).
f_c the probe **center frequency** (MHz).
Z_{sp} the axial distance at which the reported parameter is measured (cm).
x₋₆, y₋₆ are the **-6dB beam dim.** in the x-y plane where z_{sp} is found (cm).
EBD the **entrance beam dimensions** (cm). These dimensions are the same as the dimensions of the transmit crystal.

Warranty and Servicing Policy

Summit Doppler Systems, Inc. is pleased to present our customers with a 45-day no hassle evaluation return policy in the event that you are not satisfied with our product.

The warranty on this product is that it will be free from defects in material and workmanship for 15 months from the original sale of the device. This includes all parts and labor required to repair or replace the unit to original specifications and shipping costs associated with sending the product back to the customer. Customer is responsible for providing adequate packaging materials and shipping costs to Summit Doppler Systems. Products shall be repaired or replaced in a reasonable amount of time.

Summit Doppler Systems' liability for any claim is limited to materials and labor associated with repair or replacement. In no event shall Summit Doppler Systems be liable for incidental or consequential losses or damages in connection with the purchase of this product.

Summit Doppler Systems disclaims all express or implied warranties, agreements or arrangements other than issued in this warranty unless specified in writing and signed by the President of Summit Doppler Systems.

Summit Doppler Systems is not responsible for damages to the device that occur as a result of the inadequate shipping to Summit Doppler Systems, improper maintenance or cleaning as described in the user manual, misuse, abuse, alteration of the equipment from its original specifications, or dismantling the unit (other than by Summit Doppler Systems approved service technicians).

Service Returns: To return products to Summit Doppler –

1. Call Summit Doppler Systems to obtain a Return Authorization and to receive any final instructions prior to shipping
2. Clean the product prior to shipping
3. Ensure the device is well-packaged and suitable for shipment

Send the product to:

Service Department
Summit Doppler Systems, Inc.
5350 Vivian St. Suite A
Arvada, CO 80002

For customer service, technical service, cleaning, maintenance or shipping questions please call (303)423-7572